



# ULTIMATE ARCADE<sup>3</sup>

## *Pedestal* Owner's Manual



⚠ Flat Panel Television Not Included ⚠

Display Requirements: 32" to 42" Television with HDMI Input

# CHICAGO GAMING COMPANY

4616 W. 19th Street, Cicero, IL 60804 (800) 379-9776

Rev 1.0

# ULTIMATE ARCADE 3™

Thank you for purchasing Chicago Gaming Company's Ultimate Arcade 3. You can look forward to many hours of video game enjoyment. We strongly recommend that you follow the instructions and procedures as presented in this Owner's Manual and that it be read in its entirety before setting up your game.

## 1. LEGAL INFORMATION

### 1.1 SAFETY PROCEDURES

The following guidelines will help protect you and your **ULTIMATE ARCADE 3**.



Caution: For your safety follow these instructions.



Caution: Shock hazard if instructions are not followed.

- Read these instructions.
- Keep these instructions.
- Heed all warnings.
- Follow all instructions.
- Do not use this apparatus near water.
- Clean only with a dry cloth.
- Do not block any ventilation openings. Install in accordance with manufacturer's instructions.
- Do not install near any heat sources such as radiators, heat registers, stoves, or other apparatus (including amplifiers) that produce heat.
- Do not defeat the safety purpose of the polarized or grounding-type plug. A polarized plug has two blades with one wider than the other. A grounding type plug has two blades and a third grounding prong. The wide blade and third prong are provided for your safety. If the provided plug does not fit into your outlet, consult an electrician for replacement of the obsolete outlet.
- Protect the power cord from being walked on or pinched particularly at plugs, convenience receptacles, and the point where they exit from the apparatus.
- Only use attachments/accessories specified from the manufacturer.
- Unplug this apparatus during lightning storms or when unused for long periods of time.
- Refer all servicing to qualified personnel. Servicing is required when the apparatus has been damaged in any way, such as power supply cord or plug is damaged, liquid has been spilled or objects have fallen into the apparatus, the apparatus has been exposed to rain or moisture, does not operate normally, or has been dropped.
- Use with only 115 volts ~ 60Hz
- We recommend using a surge suppresser or UPS (Uninterruptible Power

- Supply) to safeguard the game from abrupt power spikes or losses.
- **WARNING:** To reduce the risk of fire or electric shock, do not expose your system to rain or moisture.
  - Do not expose your system to dripping or splashing.
  - Be sure to disconnect the power cable before working on the machine.
  - Be sure to use fuses that meet the specified rating. (5A, 220V Quick-blow). Using fuses exceeding the specified rating can cause a fire and electrical shock.
  - The game's monitor is a source of high voltage. Be **EXTREMELY CAREFUL** when working near it, high voltage charges can still be present even after you've unplugged the unit. **Have a qualified technician perform a monitor repair or replacement.**
  - Optimum operating environment is between 50-105° Fahrenheit.

### **1.2 ATARI END USER LICENSE AGREEMENT**

By accepting and operating an *Ultimate Arcade 3*, the owner (“**End User**”) of the unit agrees to abide by the terms of this agreement. Asteroids, Asteroids Deluxe, Battlezone, Black Widow, Centipede, Crystal Castles, Food Fight, Gravitar, Liberator, Lunar Lander, Major Havoc, Millipede, Missile Command, Red Baron, Space Duel, Super Break-Out, Tempest, Warlords and related logos are used under license from Atari Inc. (“**Atari**”). Atari expressly reserves the sole and exclusive ownership of the aforementioned games and all rights relating thereto. The end user hereby acknowledges that Atari is the sole and exclusive owner of the games and licensed trademarks and agrees not to challenge at any time, directly or indirectly, the rights of Atari. The end user agrees not to attempt to copy the licensed property (in whole or in part), decompile, disassemble or otherwise reverse engineer the software in any way. Atari is a third party beneficiary to this agreement and retains the right to bring action directly against an End User for breach of this End User License Agreement.

### **1.3 WARRANTY INFORMATION**

All parts are warranted against manufacturing defects for a period of 180 days. Free telephone support is available for the life of the product.

## **2. GAME SETUP**

### **2.1 INSTALLATION**

- Remove the game from its packaging.
- When moving the unit, please treat it as delicately as possible.
- Be sure to install it in a dry location.
- Plug the machine into a three-prong A/C outlet.

### **2.2 SUPPORTED TELEVISIONS**

- Ultimate Arcade 3 supports most 32” to 42” flat panel televisions, or those with VESA compliant mountings up to 400mm x 400mm.

## 2.3 KEY FEATURES

The locations of the **On/Off Switch** and **Service Button** are shown in the illustration below.

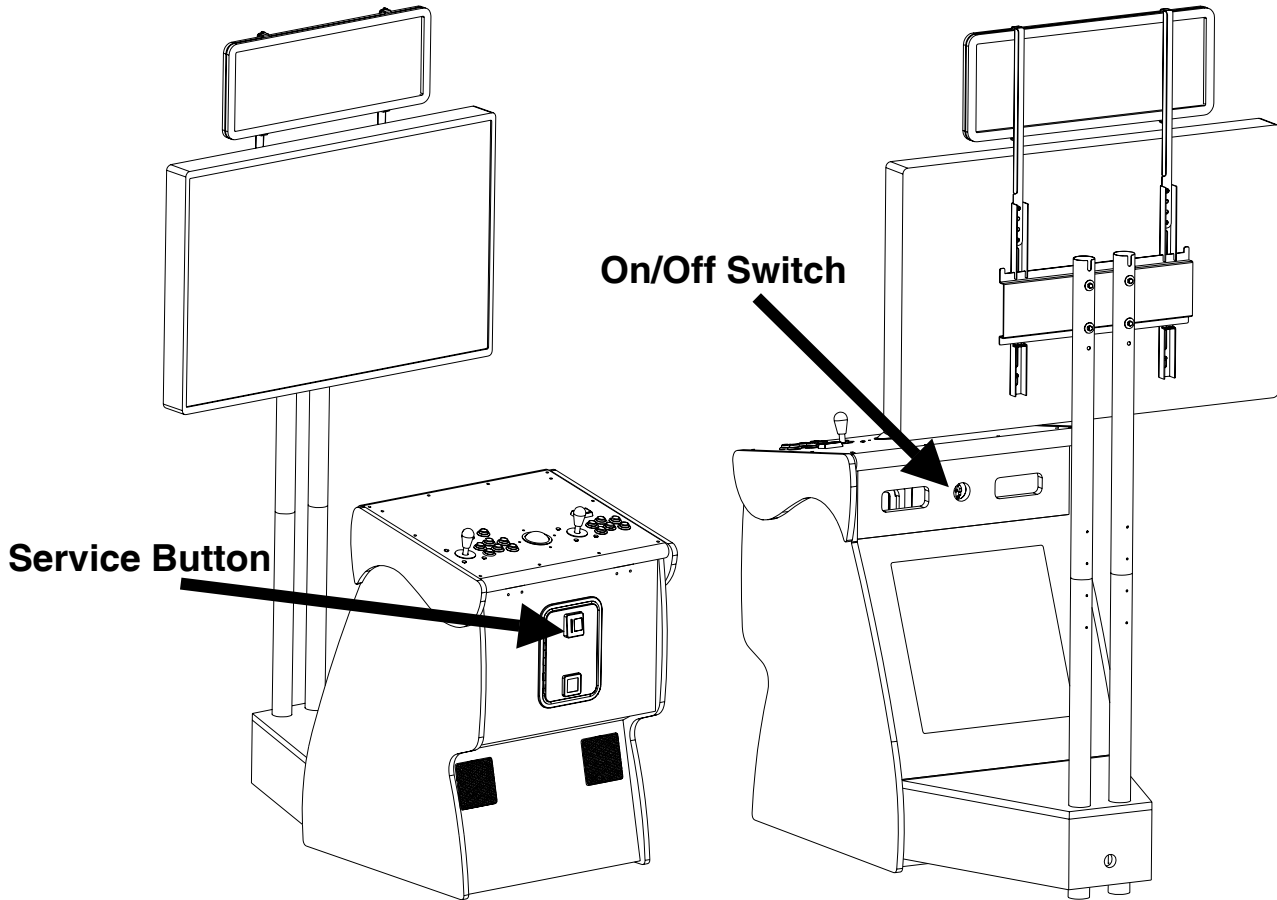

The Player 1 joystick is used to navigate the Game Select Screen and Service Menu

Player 1 and Player 2 buttons are used to start a single or two player game



Button 1 is used to make selections in the Service Menu

### 3. INSTALLATION

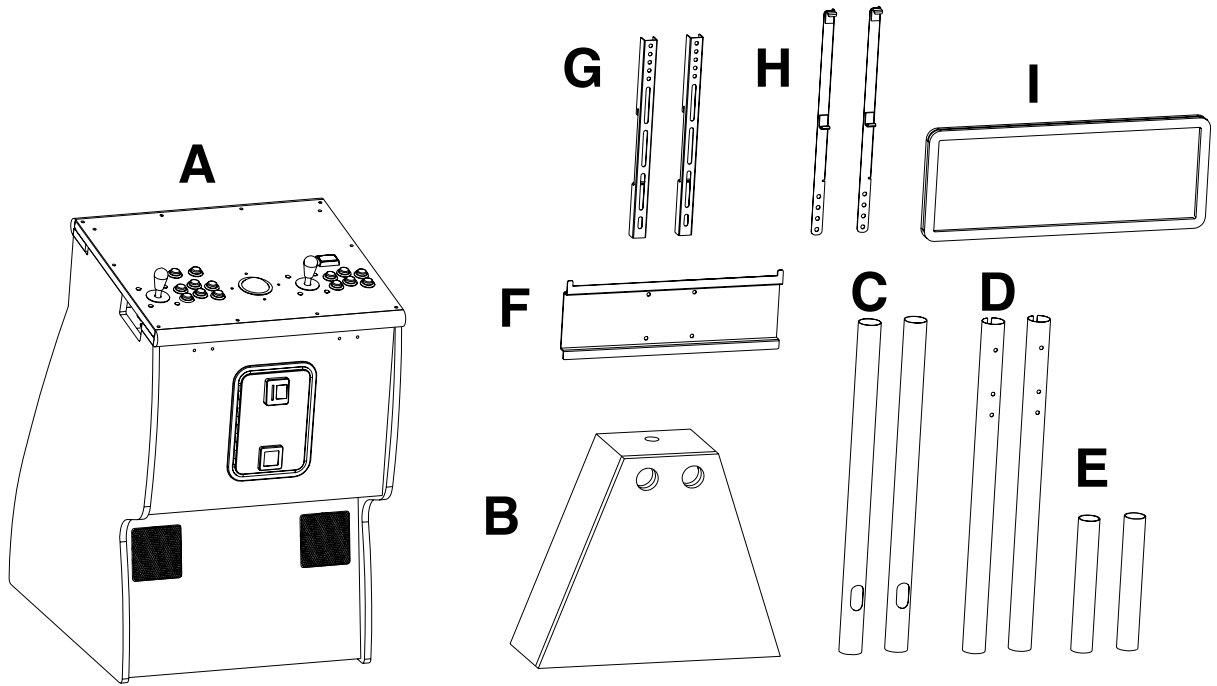

**The box contains:**

- A – Main Cabinet
- B – LCD Stand Box
- C – (2) Bottom Tubes
- D – (2) Top Tubes
- E – (2) Middle Tubes
- F – Television Mounting Bracket
- G – (2) Vertical Mounting Brackets
- H – (2) Marquee Brackets
- I – Marquee
- J – (2) Tube Caps
- K – (2) Side Panels

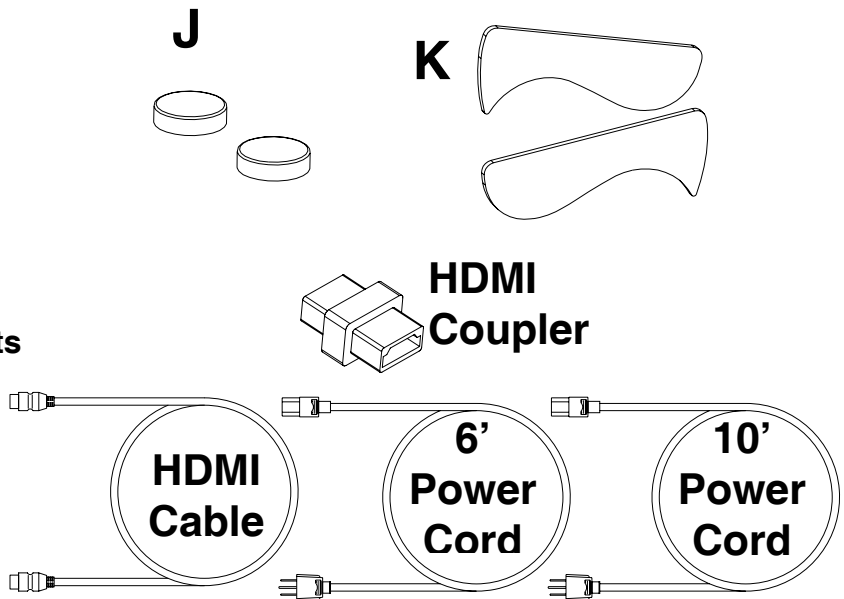

**Hardware List:**

- S1 – (4) Black 2-1/2" Hex Head Bolts
- S2 – (4) 2-1/4" Phillips Head Bolts
- S3 – (6) 8-32 Phillips Pan Head Screws
- S4 – (8) Black 1/4" Phillips Head Screws
- S5 – (12) Black 3/4" Washers
- S6 – (4) Black Acorn Cap Nuts
- S7 – (6) White Screw Caps
- S8 – (4) #6 Flat Washers
- S9 – (4) Wooden Dowels

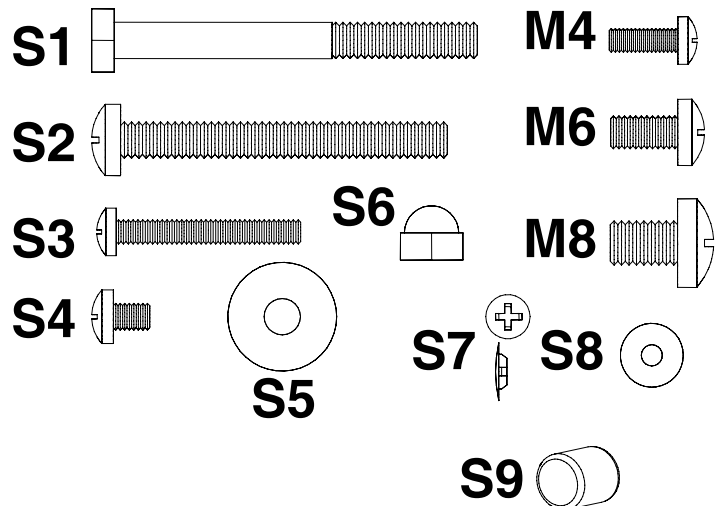

- M4 – (4) M4 Phillips Head Screws
- M6 – (4) M6 Phillips Head Screws
- M8 – (4) M8 Phillips Head Screws

Before you begin assembly, make sure the cabinet is level. Adjust the leg levelers on the bottom of the cabinet so that the cabinet is level.

Attach parts **K** to both sides of part **A** as shown to the right. Connect each piece with three **S3** screws, using the included dowels, **S9**, to align the sides. After both sides are connected and the screws are tightened, use part **S7** to cover the screw heads. Insert the caps into the head of the screw and lightly tap with a rubber mallet until the cap is flush against the cabinet.

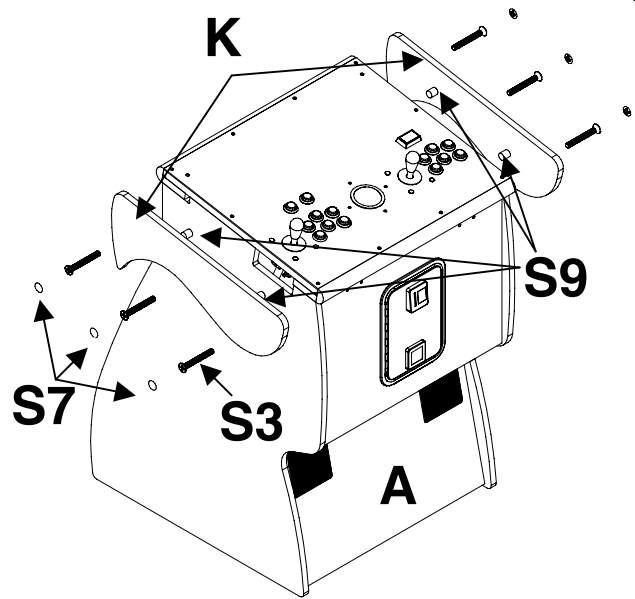

Remove the lid from part **B** and lower the leg levelers about an inch. Leave the lid off until you are finished assembling your game. You will need to connect screws and run cables through this opening.

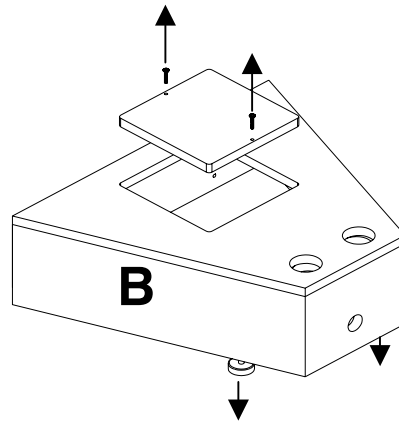

Push part **B** against the back of part **A** as shown on the right, aligning the wood block on the back of part **A** with the rectangular hole in part **B**.

Pull the HDMI Cable from the back of part **A** through the hole in part **B**, being careful not to let the cable get pinched.

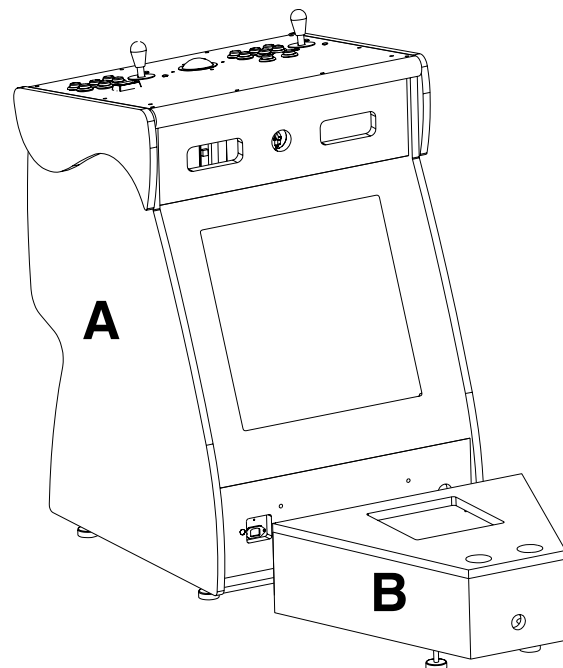

Align the square hole in part **B** with the wood block on the back of part **A**. Through the opening in part **B**, use 4 pieces of **S2** and **S5** to connect part **A** to part **B**. In the drawing on the right, the top of the box has been removed so you can more easily see where the bolts connect.

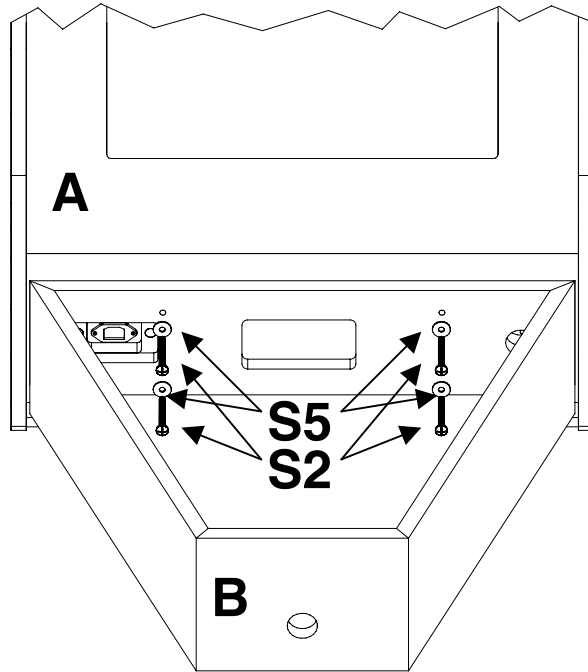

Adjust the leg levelers on part **B** so that it is level with the cabinet and the ground.



Caution: Part **B** must be supported by the leg levelers

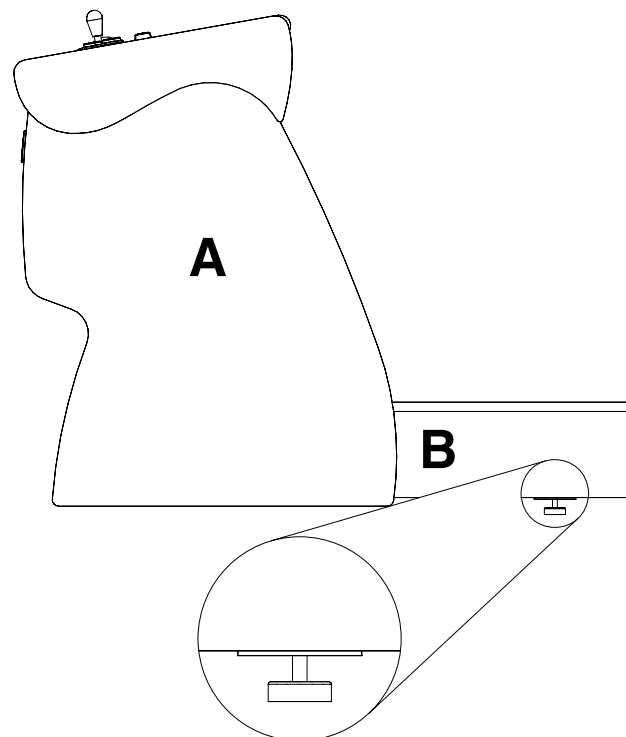

You will now assemble the Tube Stands. Both tube stands are made by connecting part **D** to part **E**, and then connecting part **E** to part **C**.



Line up the two mounting holes in part **D** with those in part **E**. Use a Phillips head screwdriver to connect them with two **S4** screws

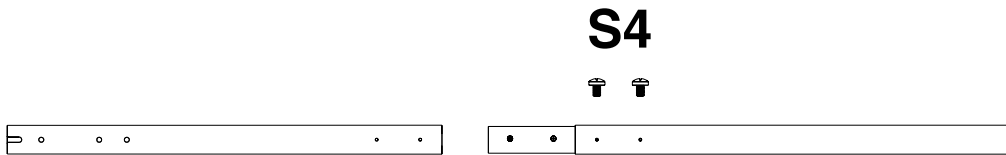

Now line up the holes in part **C** with part **E**. Use the screwdriver to connect the tubes with two more **S4** screws.

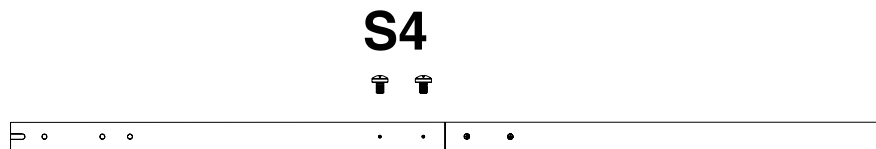

Repeat this with the other parts, and you will have two assembled tubes

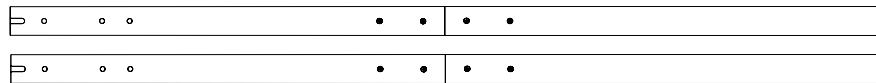

Insert the tubes into the openings at the back of part **B**. Insert them with the part **D**, side down. There should be an opening at the top of each of the tubes with a notch cut out of it. That notch must point away from the main cabinet, as shown to the right.

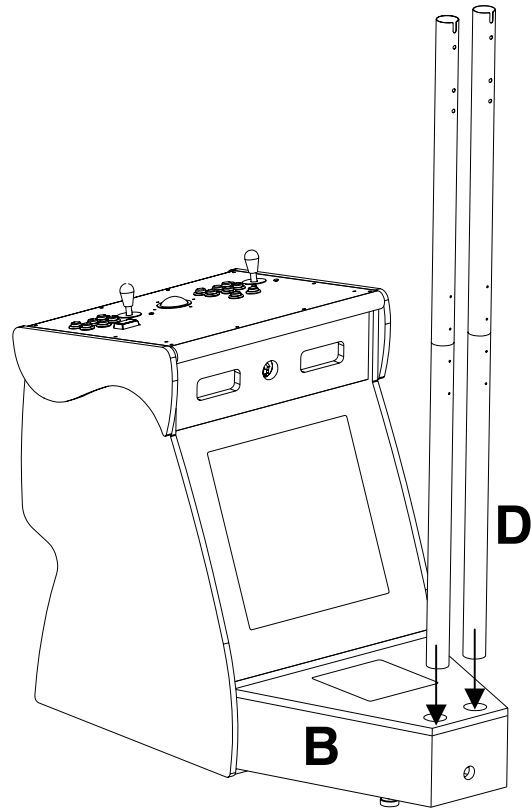

**Warning**



Make sure that the tubes **go all the way through part B and rest on the ground**, as shown to the right. Line up the tubes with the top notch pointing away from the cabinet.

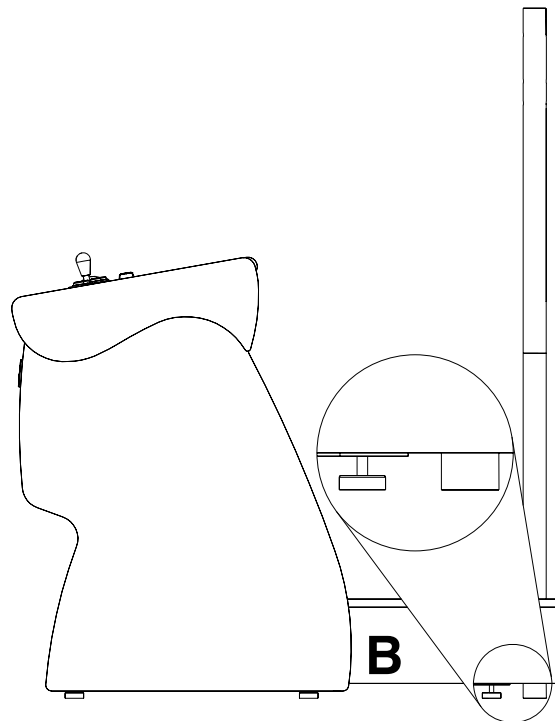

Next, you will run the HDMI cable and 10' power cord through the tubes. This is done before connecting the television so that the cables can easily pass through the tubes.

Drop one end of the HDMI cable down through the tube, and leave the other end hanging out of the top. Reach through the opening in the top of part **B** and pull the cable out of the hole in the side of the tube. Connect this end of the HDMI cable to the HDMI cable coming from the main cabinet using the HDMI adapter, shown in fig 1.

Next, drop the male end of the 10' power cord through the other tube. Reach inside the cabinet, pull the end of the cable out, and run it through the hole in the back of the cabinet.

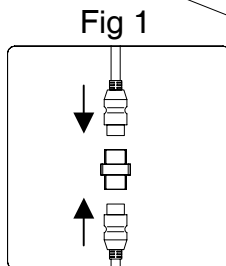
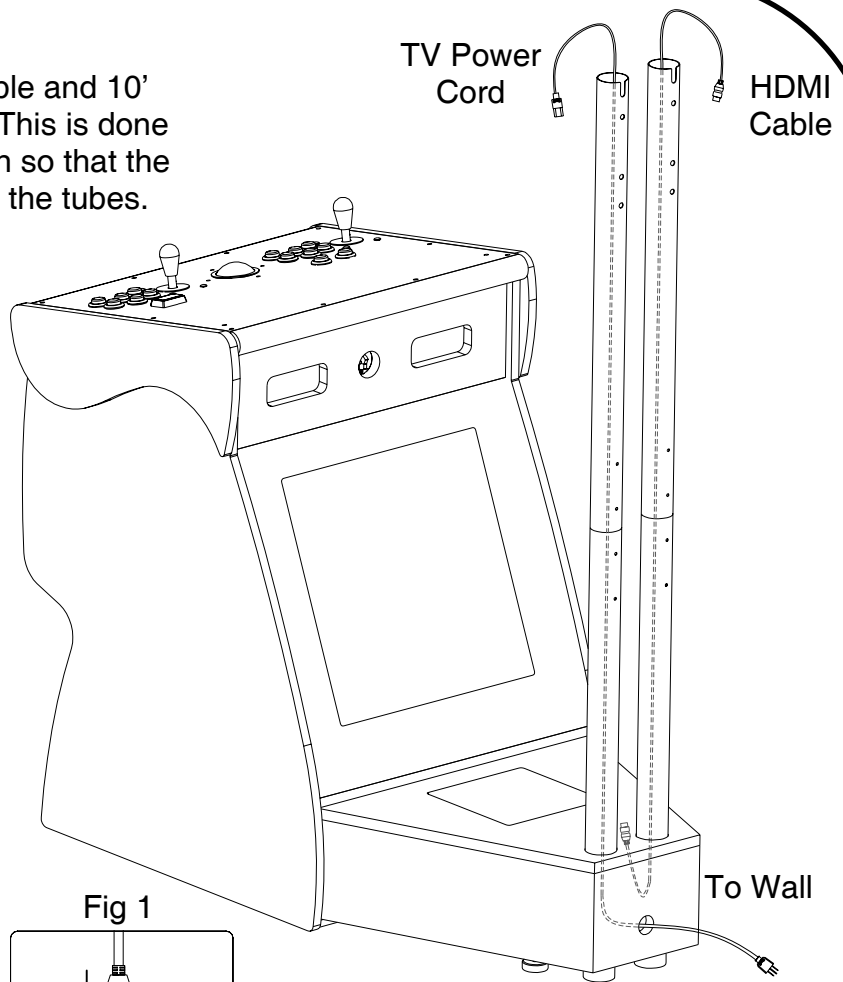

To mount part **F** to the tubes, you will need four pieces of part **S1**, four pieces of **S6**, and eight pieces of **S5**. Line up the top two holes in part **F** with the top two holes in the tubes. Use a bolt and washer to hang part **F** from the tubes. Use another washer and a nut on the other side of the tube to hold the bracket in place. Connect the other two bolts using the remaining four washers and two nuts. Make sure the bracket is level, and then tighten the nuts using a 7/16 wrench.

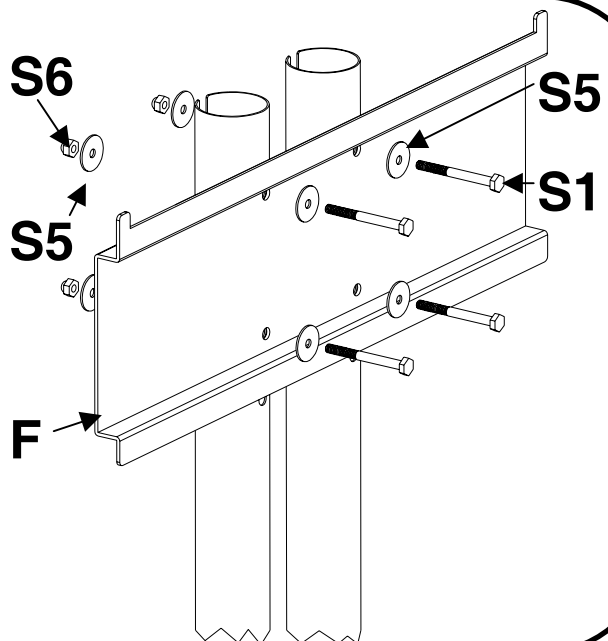

You will now connect parts **G** and **H** to the rear of your television using **M4**, **M6** or **M8** screws and four **S5** or **S8** washers. You will only need to use one size of screw and washer, which will depend on the mounting holes on the back of your television.

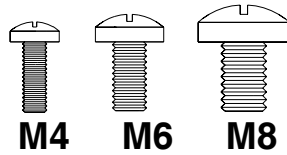

Once you have determined which screws to use, attach brackets **G** and **H** as shown below.

The top two screws go through the washer, through bracket **H**, through bracket **G**, and into the television.

Set bracket **H** at the closest height where the hooks are just above the top of the television. See fig 2 below.

Secure the bottom of bracket **G** with two more screws and washers.

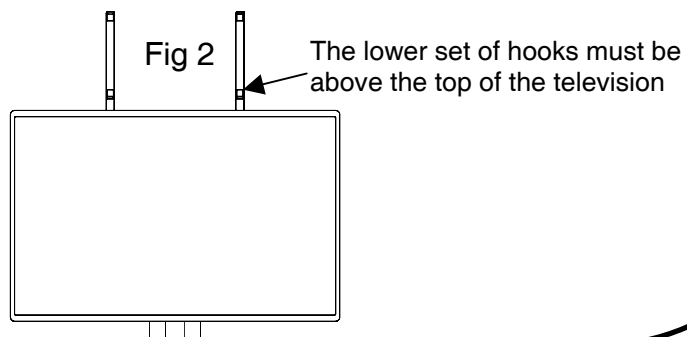
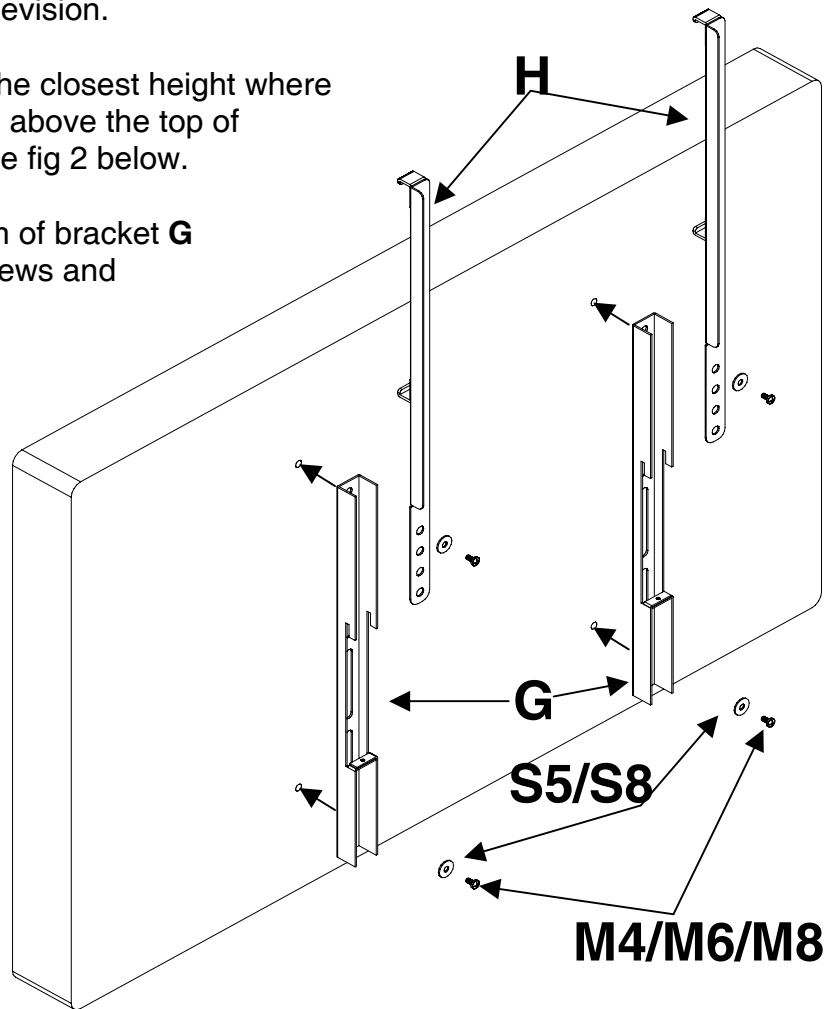

With the help of another person, hang the TV on part **F**. The hooks on the back of part **G** hang on the top edge of part **F**.

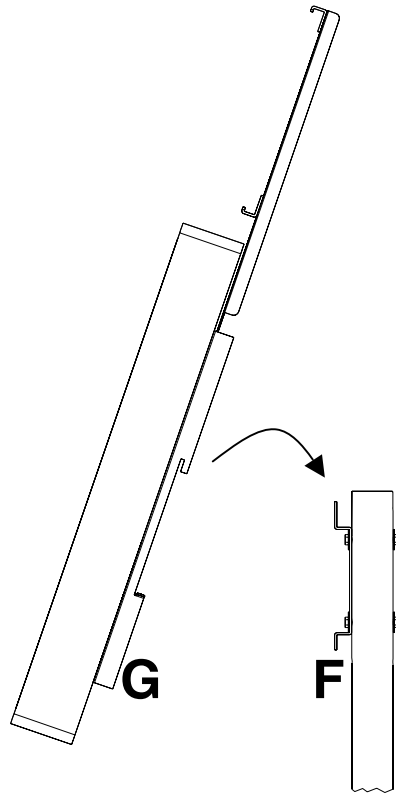

This view shows how the TV should look after hanging.

Adjust the television so that it is centered.

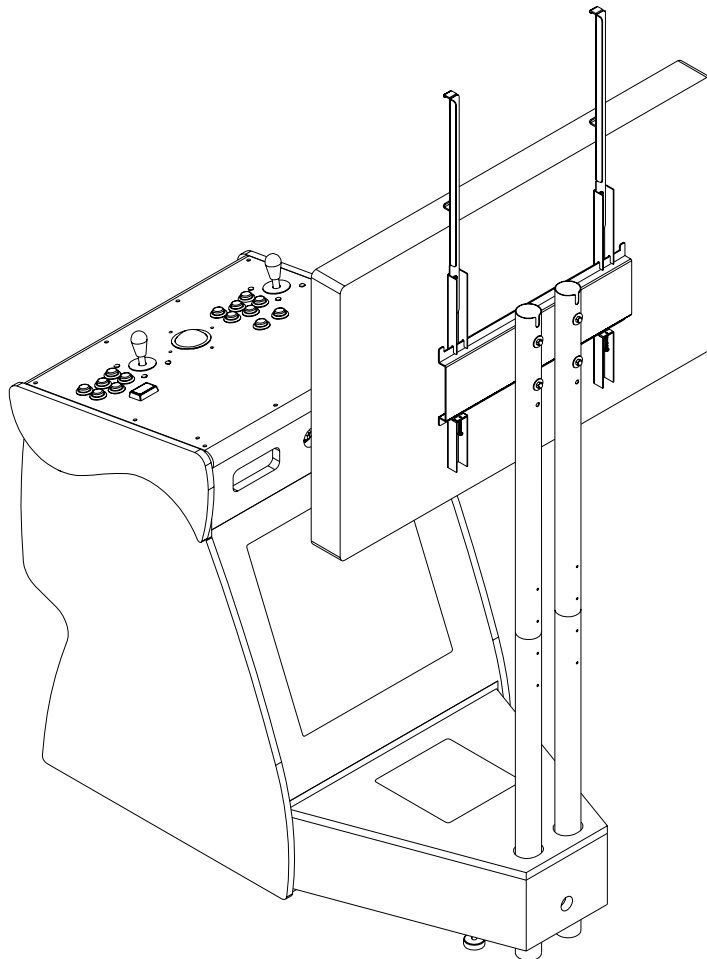

Tighten the screws at the bottom of part **G**, clamping the television to the mounting bracket.

Connect the HDMI cable and power cord, which were left hanging out of the tube earlier, to the back of your television. Run the cables through the notches at the tops of the tubes.

Attach the rubber caps, part **J**, to the tops of the tubes.

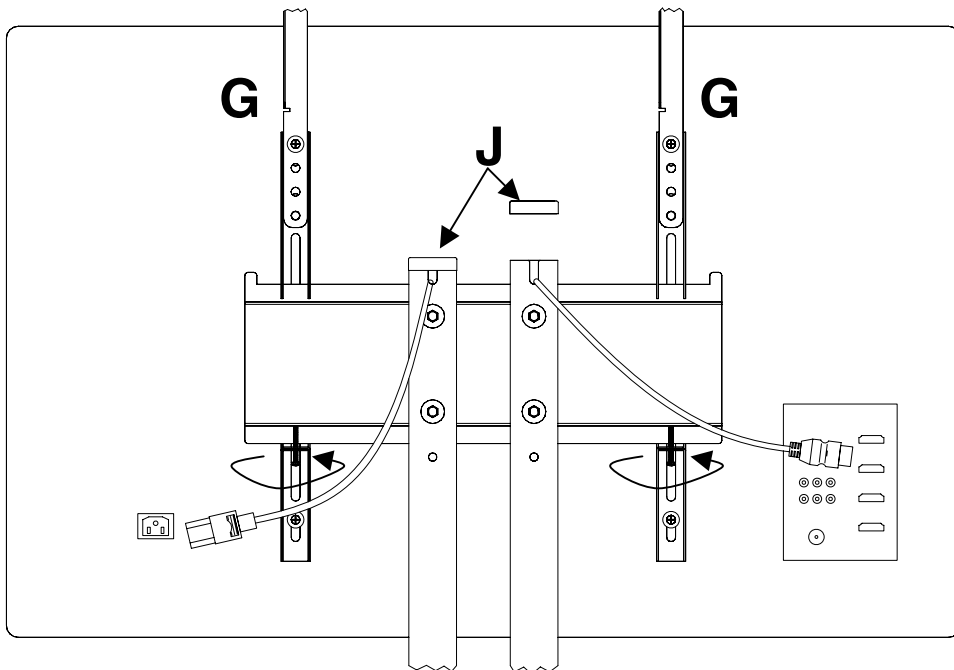

Starting from the side, slide part **I** in between the hooks on part **G**. These hooks should hold the marquee by the gap down the center.

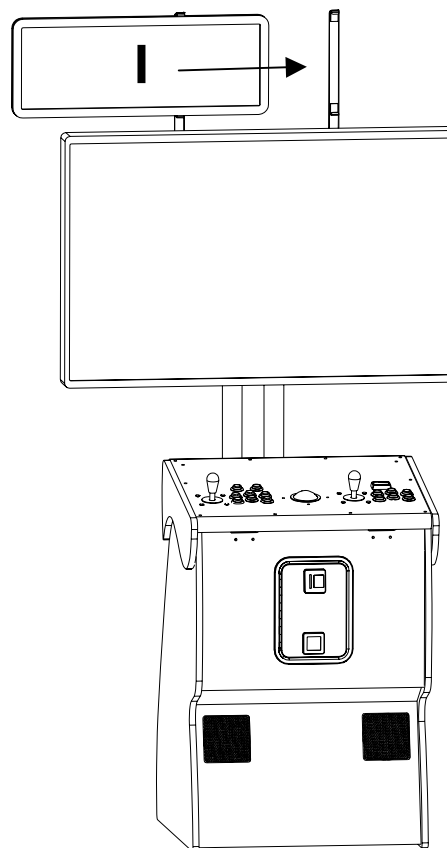

Run the 6' power cord through the hole in the back of part **B**. The 10' power cord from the television should already be coming out of this hole.

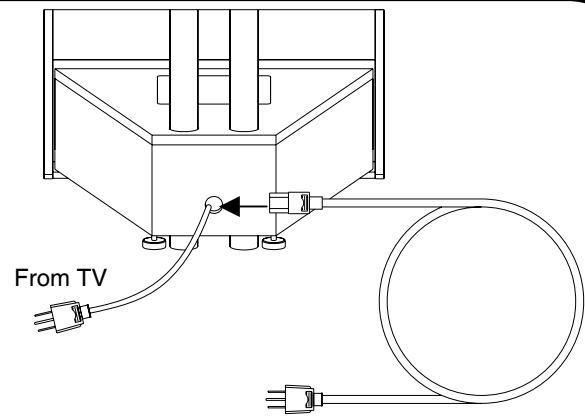

Reach inside part **B** and connect the power cord to the inlet plug, shown to the left. You now have two power cords coming out of the hole in part **B**. One powers the television, and the other powers the main cabinet.

Finally, reconnect the lid of part **B**, and secure it with the two screws you removed earlier.

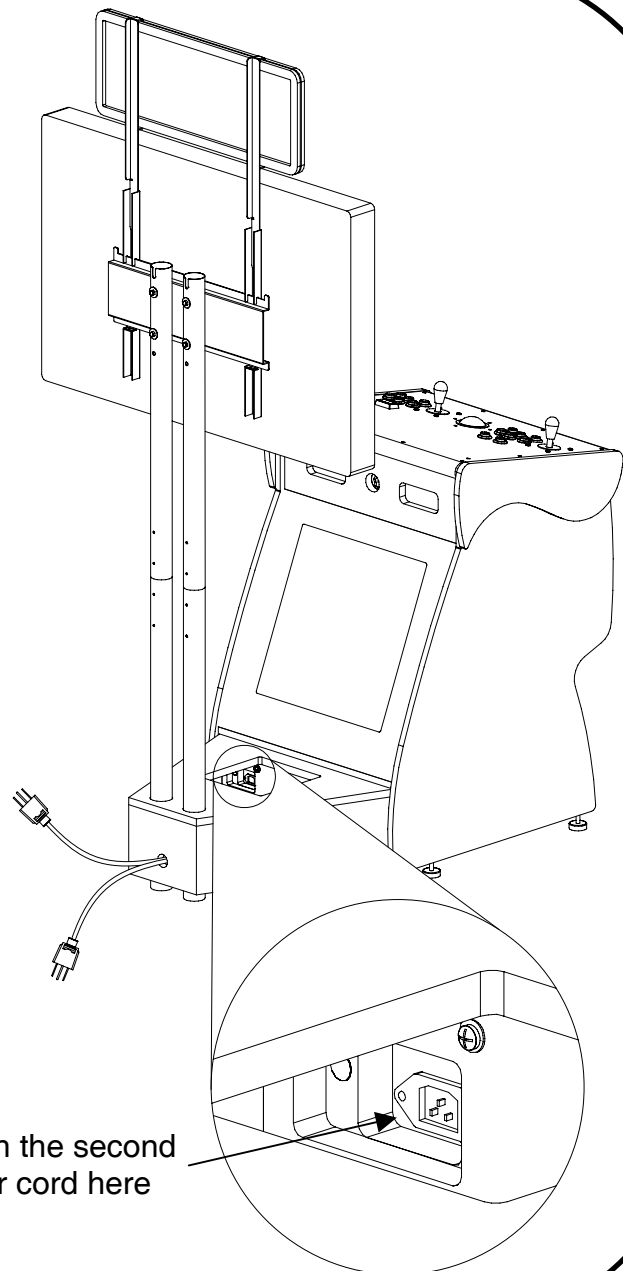

### 3. SERVICE MENU

Press the **SERVICE BUTTON**, which is located behind the faux coin-door, to access the **SERVICE MENU**. The test button can be accessed without opening the faux coin-door by pressing the coin-return button.

The **SERVICE MENU** provides access to the **ADJUSTMENTS** sub-menu and the **DIAGNOSTICS** sub-menu. To select either sub-menu, use the joystick on the Player One side (left joystick) to highlight either option, then press the button one (the upper left button in the cluster of six blue buttons) on the Player One side (left side).

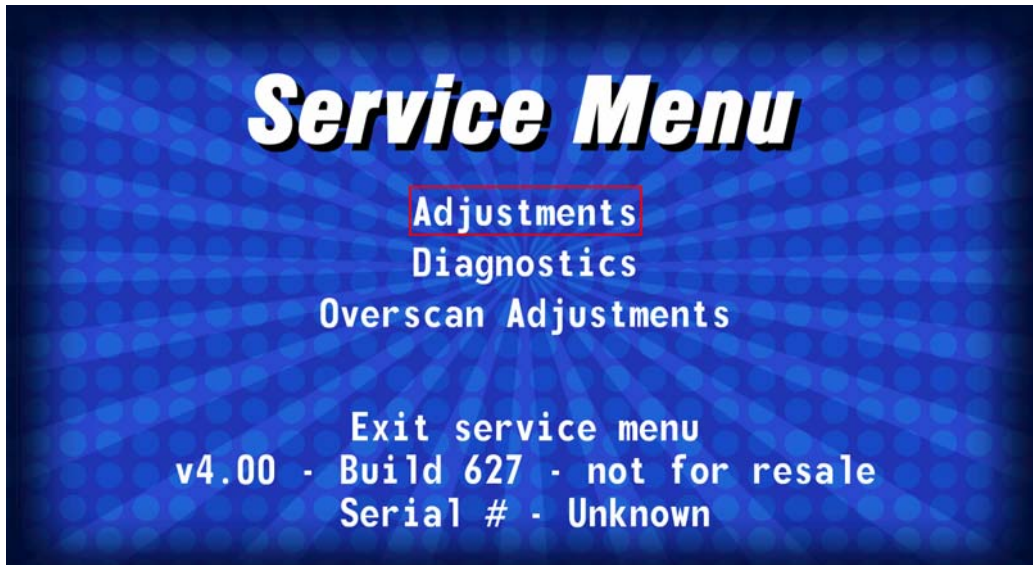

#### 3.1 ADJUSTMENTS SUB-MENU



The volume settings, which are located on the **ADJUSTMENTS** menu, which is a sub-menu of the **SERVICE** menu, allow you to independently adjust game volume and the demo mode volume.

The **GAME VOLUME** setting determines the sound level while the games are being played.

The **DEMO MODE** setting turns Demo Mode on or off. When this is on, the main menu will cycle through the games, showing a 15 second video clip of each game it stops on.

The **DEMO MODE VOLUME** setting determines the sound level at the user interface while the unit is sitting idle (in Demo Mode).

To adjust either the **GAME VOLUME** or the **DEMO MODE VOLUME**, highlight the setting you wish to adjust and press button one or two on the **PLAYER 1** side of the control panel.



The **EXIT MENU TIMEOUT** setting determines how long the exit screen will stay up before automatically exiting back to the main menu.

The **GAME IDLE TIMEOUT** setting determines how long a game will keep running when nobody is using the controls. After one or two minutes of inactivity, Ultimate Arcade 3 will automatically return to the main menu.

The **RESTORE DEFAULTS** option will return all adjustments to the factory settings.

### 3.2 DIAGNOSTICS

The **DIAGNOSTICS** menu provides tools to confirm that the controls are functioning properly and test screens which will assist in adjusting the monitor.

To select either sub-menu, use the joystick on the Player One side (left joystick) to highlight either option, then press the button one (the upper left button in the cluster of six blue buttons) on the Player One side (left side).



### 3.3 CONTROL TEST

The **CONTROL TEST** allows you to confirm the buttons, joysticks and trackballs are functioning correctly. Use of any of the controls should result in the display of the corresponding action on the monitor. Should any control cease to work contact technical support. Each of the controls can be replaced in a matter of minutes with only a phillips head screwdriver and a nut driver.



### 3.4 VIDEO TEST

This submenu provides test patterns, which assist in adjusting your monitor.

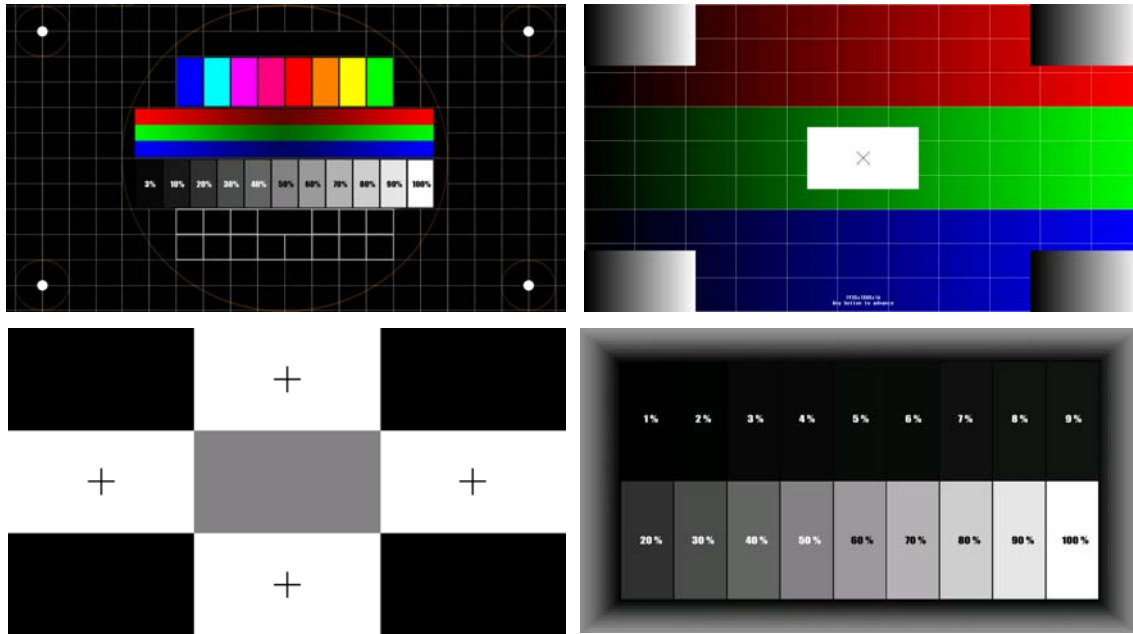

### 3.5 OVERSCAN ADJUSTMENTS

The **OVERSCAN ADJUSTMENTS** screen allows you to adjust the size of the displayed screen if it appears too large or too small. Follow the onscreen instructions to adjust overscan.

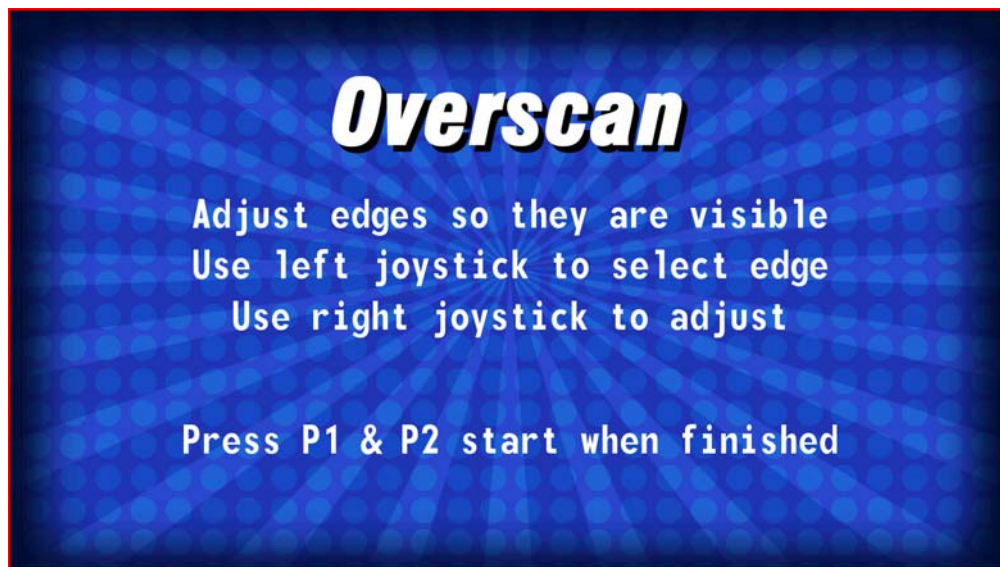

## 4. SORTING GAMES AND SELECTING GAMES

The **SORT GAMES** column allows you to reduce the total number of games displayed in the **SELECT GAMES** column; thereby allowing you to quickly find a game. To view all one hundred and twenty-five games at the same time set the **SORT GAMES** column to **ALL GAMES**.

The **SORT GAMES** column is accessed by moving the **Player 1 Joystick** right. Each subcategory is then selected by moving the Player 1 Joystick up or down. Once you have highlighted the category that you wish to select move the Player 1 joystick left to return to the **GAME SELECT MENU**.



To select a game, move the Player 1 joystick left to highlight the **SELECT GAME** column. Then move the Player 1 joystick up or down to highlight a game. Once you have highlighted the game that you wish to play, press the Player 1 start button if you wish to start a single player game or press the Player 2 button if you wish to start game for two players.

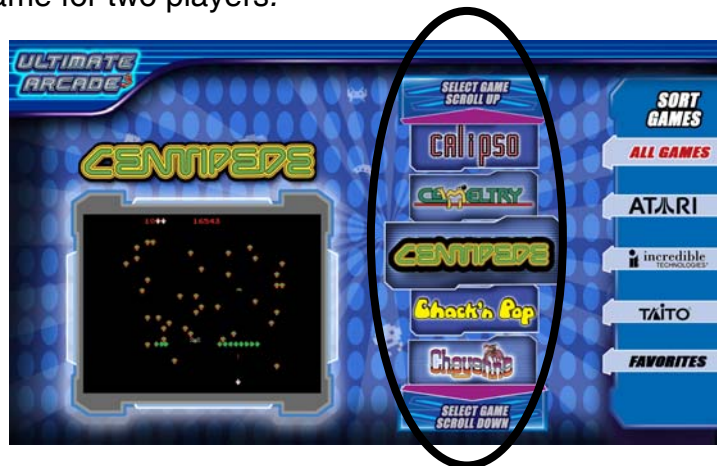

Press to Start a  
Single Player  
Game

Press to Start a  
Two Player  
Game



## 5. GAME CONTROLS INSTRUCTIONS

The **GAME CONTROLS** screen is displayed before the start of each game. This screen explains which controls are utilized in each game. To exit this screen before the default allotted time, press any button.



## 6. EXITING A GAME

To exit a game, press the **GAME EXIT** button, which is located on the upper right hand corner of the control panel. After exiting a game, you will be given the option to: **RETURN TO GAME**, **EXIT GAME**, or **ADD** or **REMOVE FROM FAVORITES**.



## 7. TECHNICAL SUPPORT

Free telephone support is provided for the *Ultimate Arcade 3* system. Technical Support is available from 9:00-5:00 Central Time, Monday through Friday. Call (708)780-0070. Select technical support in phone system menu.

## 8. GAMEPACK (UPGRADES)

Please note that *Ultimate Arcade 3* is not compatible with UltraCade/Global VR gamepacks. UPGRADES FOR ULTIMATE ARCADE OR ULTIMATE ARCADE 2 WILL NOT WORK WITH ULTIMATE ARCADE 3!!!

Please check [www.chicago-gaming.com](http://www.chicago-gaming.com) for availability of gamepacks for Ultimate Arcade 3.

## 9. FCC COMPLIANCE

**Note:** This equipment has been tested and found to comply with the limits for a Class B digital device, pursuant to Part 15 of the FCC Rules. These limits are designed to provide reasonable protection against harmful interference in a residential installation. This equipment generates, uses and can radiate radio frequency energy and, if not installed and used in accordance with the instructions, may cause harmful interference to radio communications. However, there is no guarantee that interference will not occur in a particular installation. If this equipment does cause harmful interference to radio or television reception, which can be determined by turning the equipment off and on, the user is encouraged to try to correct the interference by one of more of the following measures:

--Reorient or relocate the receiving antenna.

--Increase the separation between the equipment and receiver.

--Connect the equipment into an outlet on a circuit different from that to which the receiver is connected.

--Consult the dealer or an experienced radio/technician for help.

Changes or modifications not expressly approved in writing by Chicago Gaming Company could void the user's authority to operate the product.



